

# TEST LAMPS

## Instruction Manual

---

MTL10 (Mk3)

MTL15 (MK3)



**DRUMMOND**

# ALWAYS READ THESE INSTRUCTIONS BEFORE PROCEEDING

Thank you for buying one of our products. For safety and a full understanding of its benefits please read this manual before use.

Technical support is available from +44 (0)1923 441717 and [support@martindale-electric.co.uk](mailto:support@martindale-electric.co.uk).

## CONTENTS

<b>1</b>	<b>Safety Information</b>	<b>1</b>
1.1	Meaning of Symbols and Markings	1
1.2	Precautions	2
1.3	Safety Advice	4
<b>2</b>	<b>Introduction</b>	<b>6</b>
2.1	Inspection	6
2.2	Description	6
2.3	Accessories	6
<b>3</b>	<b>Operation</b>	<b>7</b>
3.1	Control Elements and Connections	7
3.2	Description of LED Indicators	7
3.3	Operating Duty Ratio	8
3.4	Proving Check	8
3.5	Testing for the Presence of Hazardous Live Voltage	9
3.6	Interference (Phantom) Voltage	10
<b>4</b>	<b>Maintenance</b>	<b>11</b>
4.1	Probe Replacement	11
4.2	Periodic Testing	11
4.3	Cleaning	11
4.4	Repair and Service	12
4.5	Storage Conditions	12
<b>5</b>	<b>Warranty</b>	<b>13</b>
	<b>Measurement Categories</b>	<b>15</b>
	<b>Specifications</b>	

## 1 SAFETY INFORMATION

### **REMEMBER: SAFETY IS NO ACCIDENT**

These instructions contain both information and warnings that are necessary for the safe operation and maintenance of this product. It is recommended that you read the instructions carefully and ensure that the contents are fully understood. Failure to understand and to comply with the warnings and instructions can result in serious injury, damage or even death.

Particular attention should be paid to the Warnings, Precautions and Technical Specifications.

Please keep these instructions for future reference. Updated instructions and product information are available at:  
[www.martindale-electric.co.uk](http://www.martindale-electric.co.uk)

### 1.1 Meaning of Symbols and Markings



**Caution - risk of danger & refer to instructions**



**Caution - risk of electric shock**



**Equipment protected by double or reinforced insulation (Class II)**



**Suitable for live working**





**Alternating & Direct current (AC & DC)**

**CAT IV (Measurement Category IV)** is applicable to test and measuring equipment connected at the source of the building's low-voltage MAINS installation.

For further information on measurement categories refer to page 15 or visit [www.martindale-electric.co.uk/measurement\\_categories.php](http://www.martindale-electric.co.uk/measurement_categories.php)

 **Equipment complies with relevant directives**

 **Equipment complies with relevant UK conformity assessed marking**

 **End of life disposal of this equipment should be in accordance with relevant directives**

## 1.2 Precautions

This product has been designed with your safety in mind, but please pay attention to the following warnings and cautions before use.

### **Warnings**

To avoid electric shocks, the applicable safety regulations must be observed when working with voltages above 120V (60V) DC or 50V (25V) RMS AC. The values in brackets apply to restricted voltage ranges (for example in the medical or agricultural sector).

Where applicable other safety measures such as the use of protective gloves, goggles etc. should be employed.

The voltage indicator must only be used by a skilled and competent person who is familiar with the relevant regulations, the safety risks involved and the consequent normal safe working practices.

Before each use the voltage indicator should be examined for damage, cracks, cuts or scratches to the housing, cable and prods. The cable has black outer and contrasting inner insulation, to allow

damage to the cable to be easily identified. If there is any doubt the voltage indicator should not be used.

Make sure the voltage indicator is dry, clean and free from dust, grease and moisture while in use to avoid the danger from electric shock due to surface leakage.

Before and after each use, the voltage indicator must be proven using a suitable proving device or a known good voltage source. Do not use the voltage indicator if any expected LED's fail to illuminate correctly during proving.

Testing for a voltage that exceeds the specified limits of the voltage indicator may damage the voltage indicator and may expose the operator to a shock hazard. Always check the voltage indicator's specified limits before use.

The specified measurement category means the voltage indicator will be safe to the user if connected to a voltage up to 1000V to earth on a CAT II, CAT III or CAT IV installation for MTL15. For MTL10, 1000V to earth on a CAT II or CAT III installation and 600V to earth on a CAT IV installation. It does not mean it can be used to test for a voltage beyond its maximum working voltage.

If using the voltage indicator in damp conditions, the operator must use additional protection to avoid the danger from electric shock due to surface leakage.

Select appropriate test prods and secure with captive ring nuts. The L-shaped test prods should be oriented in one of four directions using the square location feature before it is secured.

When changing or adjusting the prods, ensure that both prods have been disconnected from any source of power or other equipment.

Always keep your fingers behind the finger guards. Never touch the exposed metal prod tips.

The different indicating signals of the voltage indicator (including the ELV limit indication) are not to be used for measuring purposes.

The voltage indicator must not be dismantled or modified in any way by unauthorised persons. The safety of the voltage indicator cannot be guaranteed under such circumstances and it must not be used.

### **Cautions**

Avoid severe mechanical shock or vibration and extreme temperature.

If the voltage indicator has been stored or transported in temperatures outside its normal operating range it should be given sufficient time to stabilise in the environment where it is to be used. An acclimatisation time of at least 2 hours is required prior to operation of the voltage indicator.

### **1.3 Safety Advice**

*This section is required to be inserted verbatim by BS EN 61243-3. See [www.martindale.tips/phantom-voltage](http://www.martindale.tips/phantom-voltage) for more information on interference/phantom voltages.*

Depending on the internal impedance of the voltage detector there will be a different capability of indicating the presence or absence of operating voltage in case of the presence of interference voltage.

A voltage detector of relatively low internal impedance, compared to the reference value of 100 k $\Omega$ , will not indicate all interference voltages having an original voltage value above the ELV level. When in contact with the parts to be tested, the voltage detector may discharge temporarily the interference voltage to a level below the ELV, but it will be back to the original value when the voltage detector is removed.

When the indication “voltage present” does not appear, it is highly recommended installing earthing equipment before work.

A voltage detector of relatively high internal impedance, compared to the reference value of 100 k $\Omega$ , may not permit to clearly indicate the absence of operating voltage in case of the presence of interference voltage.

When the indication “voltage present” appears on a part that is expected to be disconnected from the installation, it is highly recommended confirming by another means (e.g. use of an adequate voltage detector, visual check of the disconnecting point of the electric circuit, etc.) that there is no operating voltage on the part to be tested and to conclude that the voltage indicated by the voltage detector is an interference voltage.

A voltage detector declaring two values of internal impedance has passed a performance test of managing interference voltages and is (within technical limits) able to distinguish operating voltage from interference voltage and has a means to directly or indirectly indicate which type of voltage is present.

## **2. INTRODUCTION**

### **2.1 Inspection**

Examine the shipping carton for any sign of damage. Inspect the unit and any accessories for damage. If there is any damage then consult your distributor immediately.

### **2.2 Description**

The MTL range test lamps are two-pole voltage indicators for universal applications. It is designed to be used by skilled persons in accordance with safe methods of work, and is constructed in accordance with the applicable safety standards to provide safe and reliable indication.

The MTL10 & MTL15 have the following features:

- ◆ MTL15: AC and DC Voltage test up to 1000V AC/DC
- ◆ MTL10: AC and DC Voltage tests up to 500V AC and 750V DC
- ◆ Bright LED indication
- ◆ Full voltage indication function without batteries
- ◆ Contrasting white coloured inner sheath to highlight cable damage and wear. Do not use if the white coloured inner sheath becomes visible
- ◆ Ergonomic and robust housing
- ◆ Probe tips comply with GS38
- ◆ Measurement category CAT IV 1000V for MTL15 & CAT IV 600V for MTL10
- ◆ Constructed in compliance with BS EN 61243-3:2014
- ◆ IP64 rated environmental protection for internal electronics

### **2.3 Accessories**

- ◆ 2 x straight prods
- ◆ 1x L-shaped prod
- ◆ Instructions



### 3. OPERATION

#### 3.1 Control Elements and Connections

- 1 - Instrument body
- 2 - LED indicator bands
- 3 - Straight prod
- 4 - L shaped prod
- 5 - Probe handle

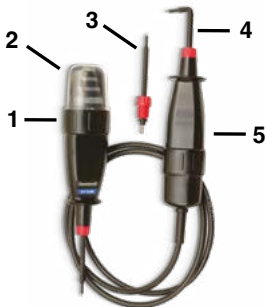

#### 3.2 Description of LED Indicators

MTL10	MTL15
<p>400V band</p> <p>230V band</p> <p>120V band</p> <p>50V band</p>	<p>690V band</p> <p>400V band</p> <p>230V band</p> <p>50V band</p>

The magnitude of a voltage is indicated by the illumination of LED's in four separate bands around the top of the instrument body.

The nominal voltage thresholds of the indicator LED bands for MTL15 are marked 50V, 230V, 400V and 690V. For MTL10 the LED bands are marked 50V, 120V, 230V and 400V.

The indicator LED bands will illuminate when the magnitude of the voltage source is at a value approaching or greater than the

corresponding marked voltage. For example if the voltage source is 55V AC rms then only the 50V indicator LED band will illuminate, if 700V AC rms all four indicator LED bands will illuminate.

**Note:** The individual LED indications are not to be used for measuring purposes.

### 3.3 Operating Duty Ratio

The voltage indicator should be operated (ON) for a maximum period of 30 seconds. This should be followed by a recovery period (OFF) of 4 minutes.

The operating duty ratio is 8 to 1, so if the voltage indicator is only ON for 2 seconds then the OFF period need only be 16 seconds.

### 3.4 Proving Check

Before each use the voltage indicator should be examined for damage, cracks, cuts or scratches to the housing, cable and prods. The cable has black outer and contrasting inner insulation, to allow damage to the cable to be easily identified. If there is any doubt the voltage indicator should **not be used**.

Before and after use, verify the voltage indicator is functioning correctly with a proving device (PD440S or PD440SRD for MTL10. PD690S or PD690SRD for MTL15.), or a known good voltage source. **Do not use** the voltage indicator if any expected voltage indication LED's fail to illuminate correctly during proving.

### **Warning**

If the proving device or voltage source exceeds the specified limits of the voltage indicator the voltage indicator may be damaged and the operator may be exposed to a shock hazard. Always check the specification of the proving device or the voltage magnitude of the voltage source before proceeding with a proving check.

The LED bands that illuminate during proving will depend on the magnitude of the proving unit output or the voltage source. For example if the voltage source is 400V then all LED bands except the 690V LED band must illuminate.

Any unexpected display should be investigated and the voltage detector **not used** until all expected LED's illuminate.

### **3.5 Testing for the Presence of Hazardous Live Voltage**

#### **Warning**

Hold the unit and test leads behind the finger guards in a manner that will not obscure the voltage band indication LED's. Never touch the exposed metal test prods or any part of the instrument forward of the finger guards while applied to hazardous voltages.

While taking all required safety precautions connect the test prods across the test points where a voltage difference may be present.

The voltage level of any voltage present between the test points will be indicated by the illumination of the relevant voltage indicator LED bands.

### **3.6 Interference (Phantom) Voltage**

It is possible for wiring that is 'dead' to indicate the apparent presence of voltage at power frequency.

If wiring that is live is running in close proximity to the 'dead' wiring being tested, there can be capacitive or inductive coupling between the two, thereby causing interference (phantom) voltage.



Refer to section 1.3 for safety advice relevant to interference voltage.

## 4. MAINTENANCE

### 4.1 Probe Replacement

If the test prods become damaged they should be replaced.

Replacement prods are available as spare items:

- ◆ Straight prod (DRUMTL2104)
- ◆ L-shaped prod (DRUMTL2105)

Contact your local distributor or contact Martindale Electric on +44 (0)1923 441717 or email [sales@martindale-electric.co.uk](mailto:sales@martindale-electric.co.uk).

### 4.2 Periodic Testing

To maintain the integrity of the voltage indicator, Martindale Electric recommends that it is returned at least once a year to verify physical integrity, electrical specification and insulation integrity.

Martindale Electric is pleased to offer you this service. Please contact our Service Department for details.

Email: [service@martindale-electric.co.uk](mailto:service@martindale-electric.co.uk)

Tel: +44 (0)1923 650660

### 4.3 Cleaning



#### Warning

To reduce the risk of surface leakage, this instrument must be kept in a clean condition.

Prior to cleaning, ensure that the instrument is disconnected from any voltage source.

Wipe the voltage detector with a cloth soaked with alcohol or mild non-conductive detergent. Particular attention should be paid to all areas forward of the finger guards. Do not use abrasives, abrasive solvents or detergents which can cause damage to the voltage detector. Allow the voltage detector to thoroughly dry before use.

If contamination is found, clean with a damp soft cloth and if necessary a mild detergent or alcohol. Do not use abrasives, abrasive solvents, or detergents which can cause damage to the unit. If a mild detergent is used, the unit should subsequently be thoroughly cleaned with a water dampened soft cloth. After cleaning, dry and allow to remain in a dry environment for 2 hours before use.

#### **4.4 Repair and Service**

There are no serviceable parts in this unit. The product is a sealed unit and **must not** be opened for any reason.

#### **4.5 Storage Conditions**

The instrument should be kept in cool, dry conditions and not subjected to shock, scratching or other damage, prolonged direct harsh sunlight, extremes of temperature and in such a manner as to preserve the working life of the unit. It is strongly advised that the unit is not kept in a tool box where other tools may damage it.

## **5. WARRANTY AND LIMITATION OF LIABILITY**

Drummond products by Martindale – this product is warranted to be free from defects in material and workmanship under normal use and service. The warranty period is 2 years and begins on the date of receipt by the end user. This warranty extends only to the original buyer or end-user customer, and does not apply to fuses, disposable batteries, test leads or to any product which, in Martindale's opinion, has been misused, altered, neglected, contaminated, or damaged by accident or abnormal conditions of operation, handling or storage.

Martindale authorised resellers shall extend this warranty on new and unused products to end-user customers only but have no authority to extend a greater or different warranty on behalf of Martindale.

Martindale's warranty obligation is limited, at Martindale's option, to refund of the purchase price, free of charge repair, or replacement of a defective product which is returned to Martindale within the warranty period.

This warranty is the buyer's sole and exclusive remedy and is in lieu of all other warranties, expressed or implied, including but not limited to any implied warranty of merchantability or fitness for a particular purpose. Martindale shall not be liable for any special, indirect, incidental or consequential damages or losses, including loss of data, arising from any cause or theory.

Since some jurisdictions do not allow limitation of the term of an implied warranty, or exclusion or limitation of incidental or consequential damages, the limitations and exclusions of this warranty may not apply to every buyer. If any part of any provision

of this warranty is held invalid or unenforceable by a court or other decision-maker of competent jurisdiction, such holding will not affect the validity or enforceability of any other provision or other part of that provision.

Nothing in this statement reduces your statutory rights.



## MEASUREMENT CATEGORIES

### CAT Ratings

BS EN61010-1 Installation

Categories (CAT ratings) define the risks from hazardous transient impulses and potentially lethal short circuit currents on the mains supply system based on where you are working.

### Voltage Ratings

Test equipment used for measuring mains circuits will have a CAT rating to show where it can be used. Each category also has a voltage rating to show the maximum safe phase to earth system voltage, normally 50V, 100V, 150V, 300V, 600V or 1000V.

**Stay safe - Match your test equipment safety rating to the installation category.**

**CAT II:** Socket outlets and similar points of the mains installation.

**CAT III:** The distribution part of the building's mains installation.

**CAT IV:** The supply side source of the building's mains installation.

**Testers, leads and accessories all need safety ratings equivalent to, or higher than the installation category and voltage rating for the location to be safe.**

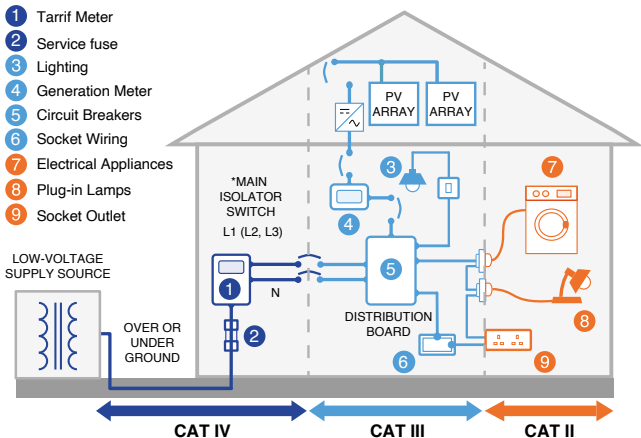

**DRUMMOND**

# Specification

## MTL10 & MTL15 (MK3)

### Drummond Test Lamp

---



#### Electrical

MTL10 maximum working voltage:  
500V AC, 750V DC

MTL10 nominal voltage threshold  
indications: 50, 120, 230, 400V AC/DC

MTL15 maximum working voltage:  
1000V AC/DC

MTL15 nominal voltage threshold  
indications: 50, 230, 400, 690V AC/DC

Nominal voltage threshold tolerance:  
Conforms to BS EN 61243-3:2014

Internal impedance at ELV a.c.: 16k $\Omega$

Range detection: Automatic

Response time: <0.1s

Frequency range: DC, 40-65Hz

Test current: <3.5mA

Duty ratio: 30s ON (operated) / 240s  
OFF (recovery)

#### EMC

Conforms to BS EN IEC 61326-1

#### Environmental

Temperature (Operating & Storage):  
-10°C to 55°C

Humidity (Operating & Storage):  
 $\leq$  85% R.H.

Altitude: up to 2000m

Pollution degree: 2

#### General

Power: from circuit under test

Dimensions:

213(L) x 112(W) x 72(D) mm

Weight packed: 320g approx

Includes:

- 2 x straight prods
- 1 x L-shaped prod
- Instructions

#### Safety

Conforms to BS EN 61243-3:2014

MTL15 CAT IV 1000V

MTL10 CAT IV 600V

Probe tips comply with GS38

Class II, double insulation

IP rating: IP64

#### Prod specification

**MTL2106** - Straight prod  
long 130mm

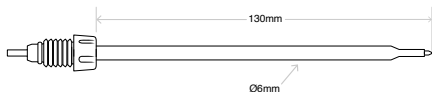

**MTL2107** - Angled prod  
long 130mm

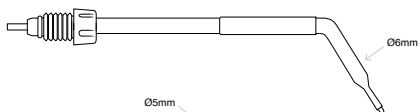

**MTL2108** - Straight prod  
Australian 62mm

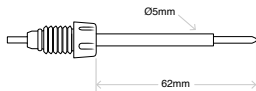

**MTL2104** - Straight prod  
standard 62mm (included)

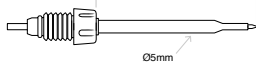

**MTL2105** - L shaped prod  
standard 62mm (included)

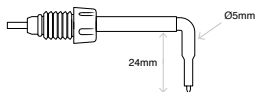

**MTL2103** - Straight prod  
short 30mm

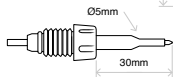

Probe tip detail - GS38 compliant  
(excluding MTL2108)

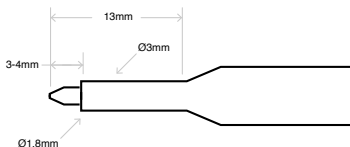

## Check out what else you can get from Martindale:

- 18th Edition Testers
- Accessories
- Cable Locators
- Calibration Equipment
- Continuity Testers
- Digital Clamp Meters
- Digital Multimeters
- Electricians' Kits
- Environmental Products
- Full Calibration & Repair Service
- Fuse Finders
- Labels
- Microwave Leakage Detectors
- Multifunction Testers
- Pat Testers & Accessories
- Phase Rotation Testers
- Proving Units
- Safe Isolation Kits
- Socket Testers
- Specialist Drummond Testers
- Thermometers & Probes
- Test Leads
- Voltage Indicators

Drummond products by Martindale Electric Co. Ltd. Metrohm House,  
12 Imperial Park, Imperial Way, Watford WD24 4PP. T: +44 (0)1923 441717  
[www.martindale-electric.co.uk](http://www.martindale-electric.co.uk) [sales@martindale-electric.co.uk](mailto:sales@martindale-electric.co.uk)

### Ver. D1.0

Due to policy of continuous development, Martindale Electric reserves the right to alter equipment specification and description outlined in this document without prior notice. No part of this document shall be deemed to be part of any contract for the equipment unless specifically referred to as an inclusion within such contract. © 2023 Martindale Electric Co. Ltd. Registered in England No. 3387451. LITMTL10-15